

Heavy Armoured Car with 7,5 cm gun Sd.Kfz. 234/3

Ciężki samochód pancerny

1/35 scale update for Italeri

ABER® 35 077

Made in Poland © 2004

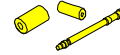
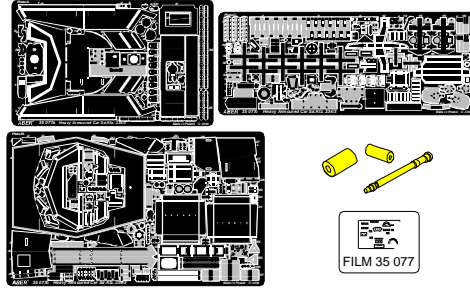

Bibliography:

1. "Schwerer Panzerspähwagen (Sd.Kfz.234)", MOS No 24, Darlinton Productions Inc., Darlinton 1998
2. "German 8-wheeled armored car(2), Ground Power No 074, Delta Publishing, Tokyo 2000
3. "Sd.Kfz.234", Photosniper No 20, Kagero, Lublin 2004
4. "Sd.Kfz.234", Armor Photogallery No 4, Progres Publishing House, Warszawa 2003

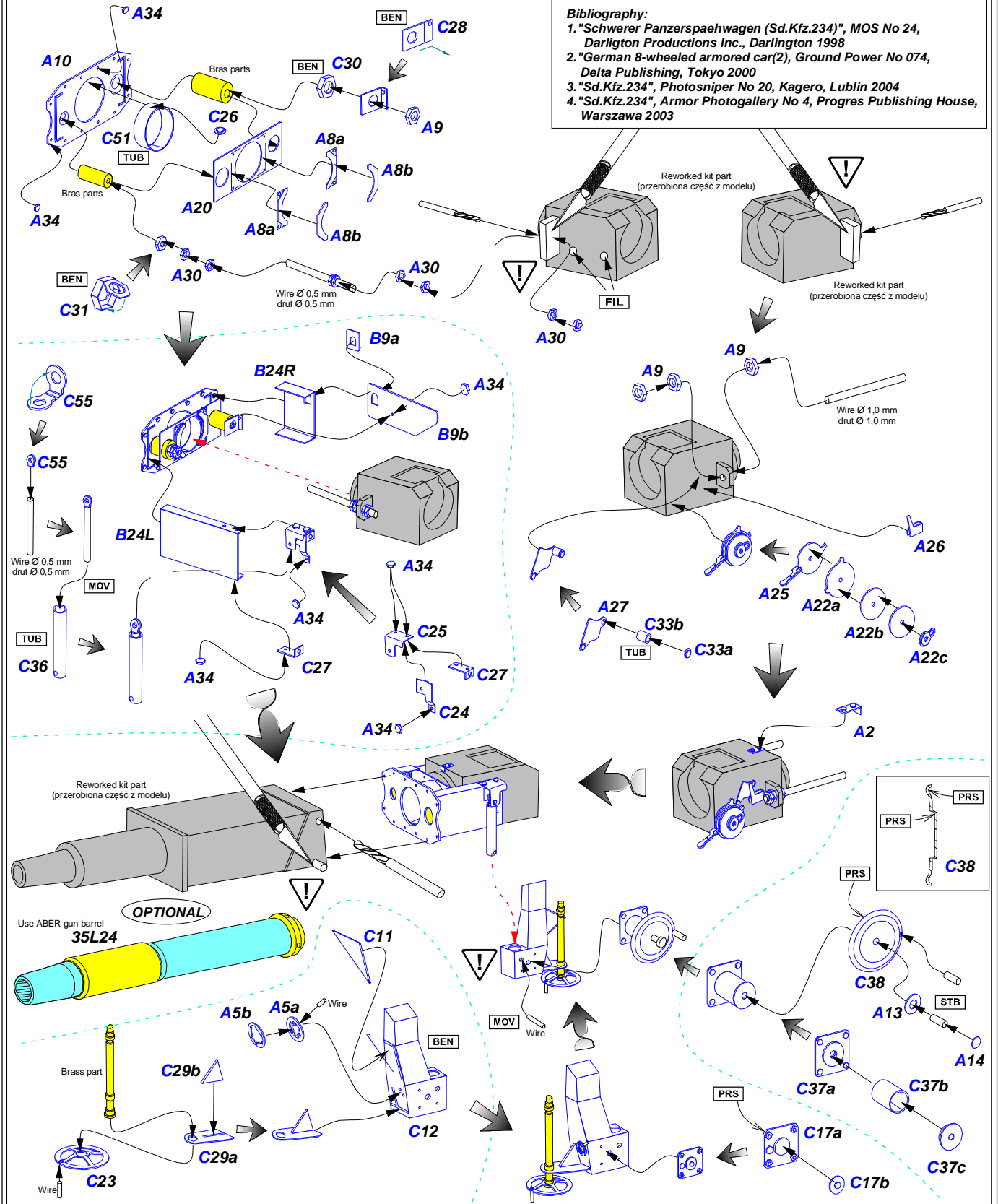

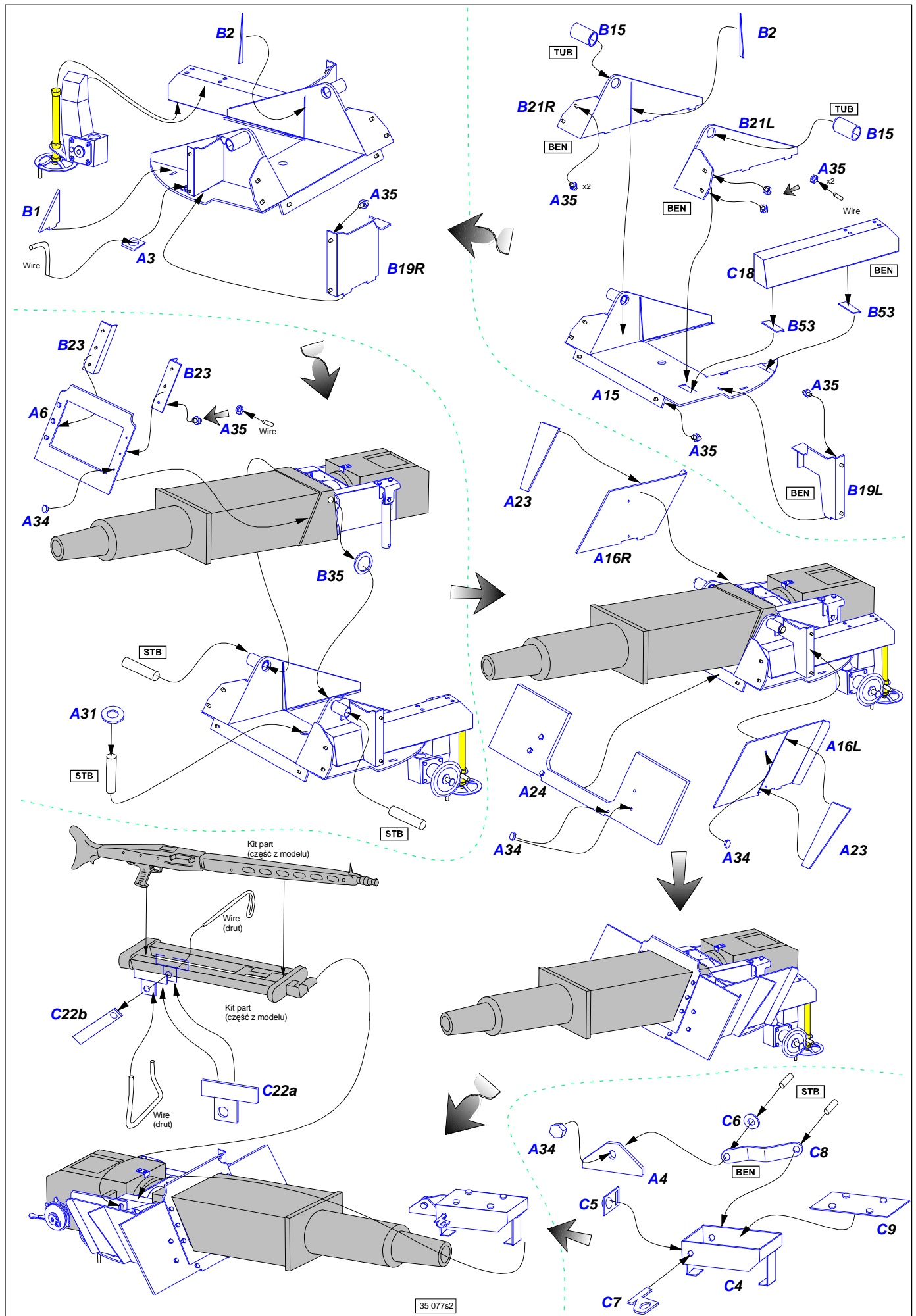

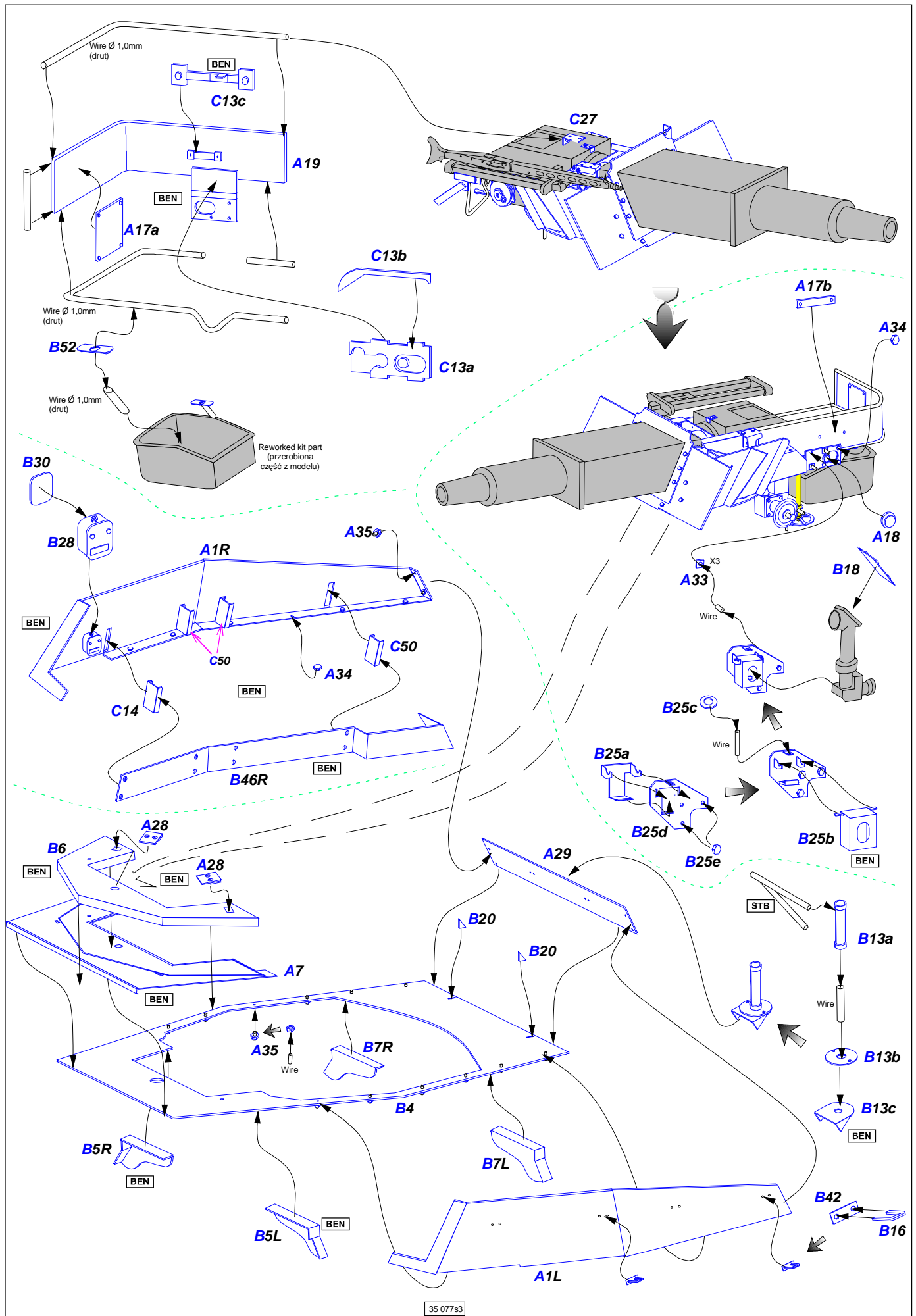

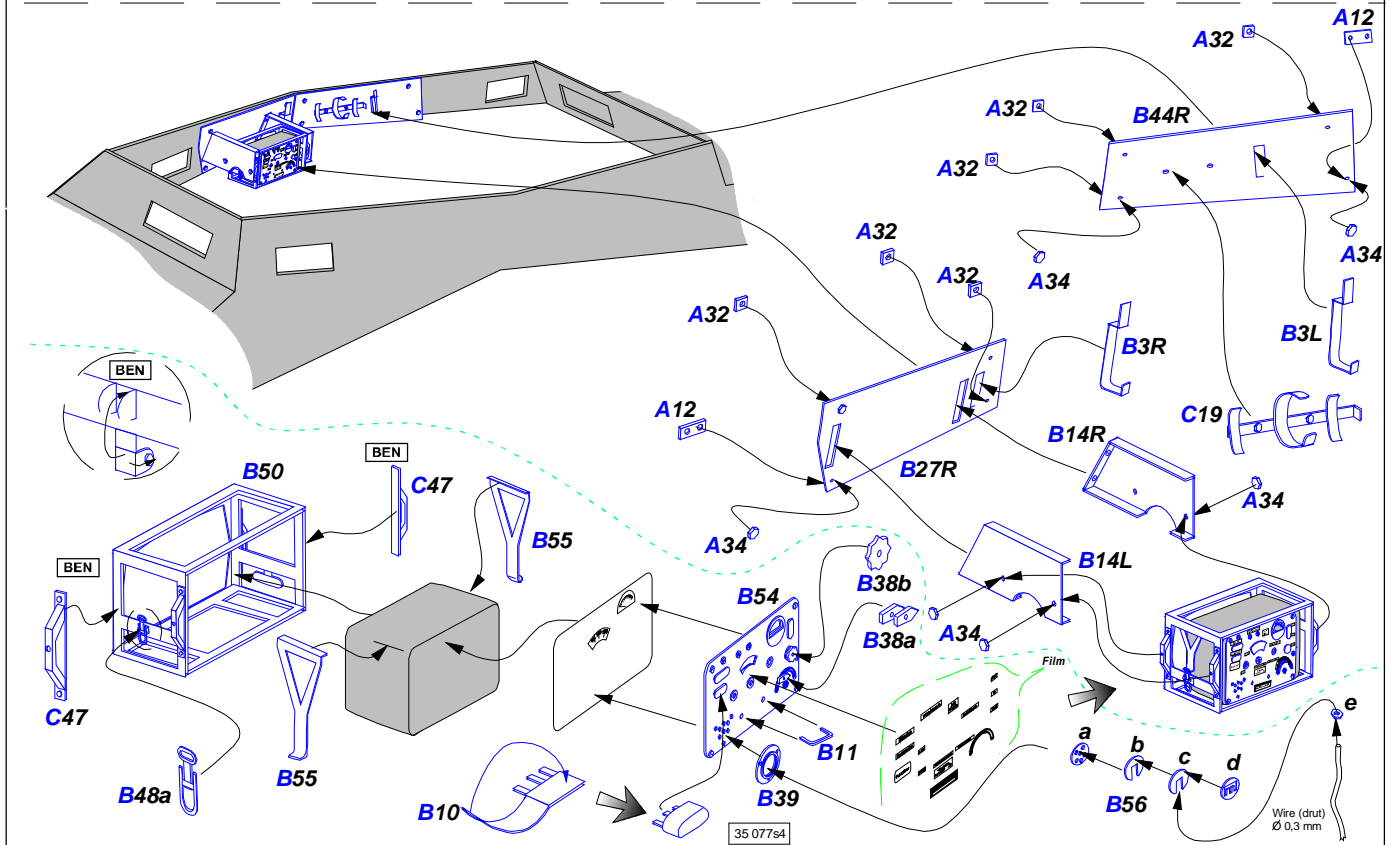
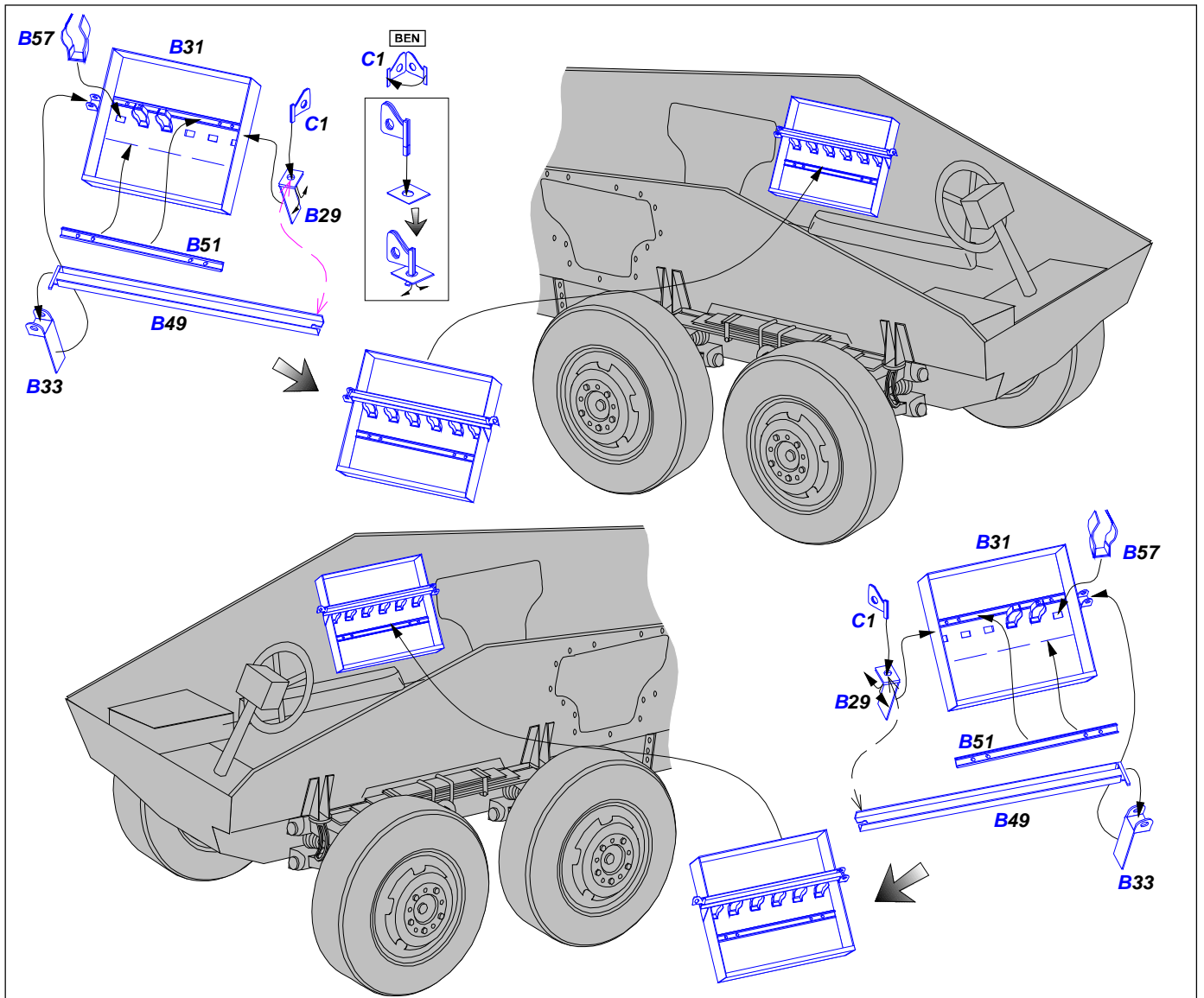

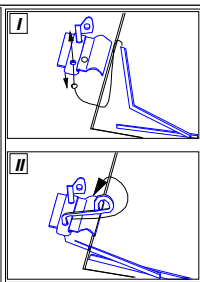
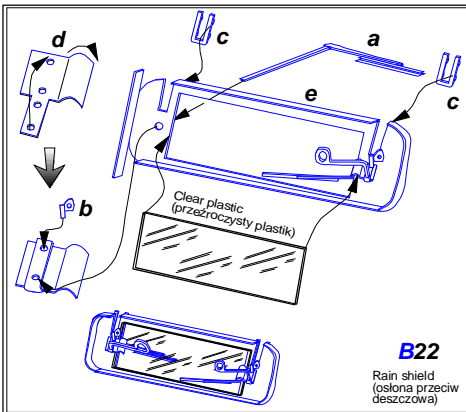

Separately sold (oddzielnie w sprzedaży):
 -35 A30 Side bin doors for Sd.Kfz.234 (Dźwiczki do bocznych schowków)
 -35 A77 Engine upper deck for Heavy Armoured Car Sd.Kfz. 234 (Górne pokrywy przedziału silnikowego do ciężkiego samochodu pancernego)
 -35 L-24 German 75 mm K 51 L/24 Barrel for Sd.Kfz. 234 (Lufa)
 -R-20 German with indicators for Sd.Kfz. 234 (Skrajnia obrysu)

